

SECTION A-A

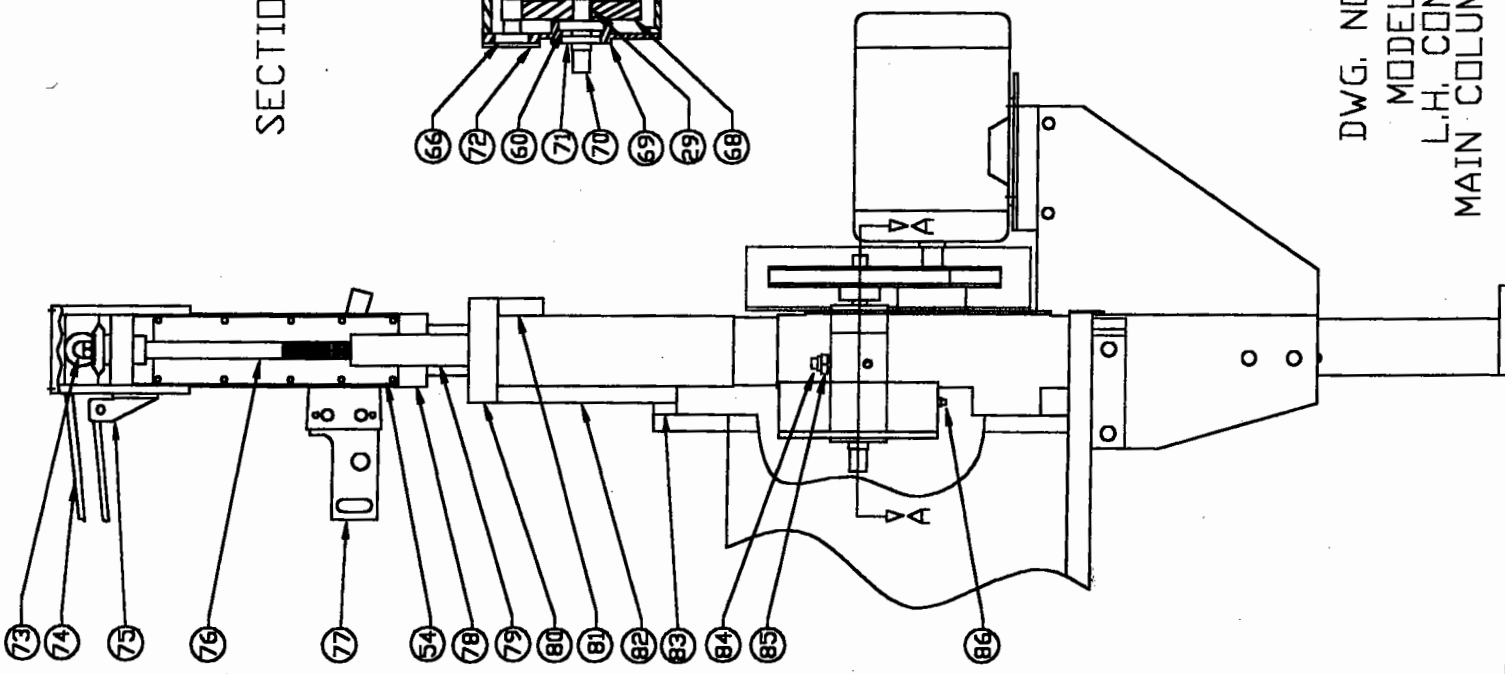
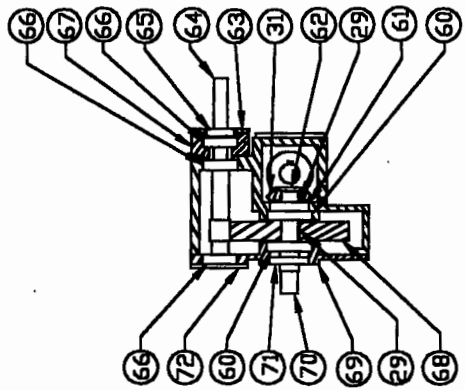

DWG. NO. NAL-A18LRC  
 MODEL A7RC/APRC  
 L.H. CONTROL LABELER  
 MAIN COLUMN DRIVE ASSEMBLY

## MODEL A7RC/APRC L.H. CONTROL LABELER MAIN COLUMN DRIVE ASSEMBLY

DWG. NO. NAL-A18LRC

ITEM NO.	PART NO.	DESCRIPTION
1	NLE-5303	OVERHEAD CARRIER ARM KEY
2	NLE-560	OVERHEAD CARRIER BAR
3	NLE-559D	OVERHEAD CARRIER ARM - D.E.
4	NLE-5333	CARRIER ARM CAP - D.E.
5	NLE-BS8F	BEARING
6	NAL-557DRC	COUNTER DRIVE SHAFT
7	NAL-561	SUPPORT SHIELD
8	NLE-5337/1	DRIVEN PULLEY 8"
9	NAL-5130L6X8	MOTOR DRIVE BELT
10	NLE-5336	DRIVE PULLEY 6"
11	NLE-5335/2	MOTOR 1-1/2 HP (230/460-3-60)
12	NAL-1945	MOTOR MOUNT PLATE
13	NL-5203	BRONZE BUSHING
14	FP-SC10	SET COLLAR
15	NAL-1944	MOTOR ADJUST SCREW
16	NLE-C202	WASHER
17	NL-527	BRONZE BUSHING
18	NL-443	HANDWHEEL
19	NAL-1940	MOTOR ADJUST SUPPORT
20	NAL-1942	MOTOR ADJUST SLIDE BLOCK
21	NAL-1943	MOTOR ADJUST SLIDE ROD
22	NAL-1941	MOTOR ADJUST SLIDE BLOCK
23	NAL-1949	MOTOR SUPPORT BRACE
24	NAL-530	DIAMETER ADJUST BEARING SUPORT
25	NLE-535	DIAMETER ADJUST SPROCKET
26	NMC-149	FLANGE BUSHING
27	NLE-454	HEIGHT ADJUST TAKE-UP ROLLER
28	NLEB-46	BOOSTER DRIVE CAP
29	NLE-566	COUNTER DRIVE SHAFT KEY
30	NAL-5341R	DRIVE SHAFT SCREW-R.H.
31	NLE-596	DRIVE GEAR
32	NAL-520	TUBING THRUST COLLAR
33	NL-B608	THRUST BEARING
34	NLE-522	DIAMETER ADJUST BEVEL PINION
35	NAL-1906	DIAMETER ADJUST GEAR COVER
36	FP-HN08F	PLATED HEX NUT
37	NLE-453	HEIGHT ADJUST STUD WASHER
38	NLE-521	DIAMETER ADJUST BEVEL GEAR
39	NAL-1904	THRUST ADJUST NUT MOUNT
40	NLE-519	THRUST ADJUST NUT
41	NAL-1905	DIAMETER ADJUST SCREW FILLER
42	NAL-1903	DIAMETER ADJUST GEAR SUPPDRT
43	NAL-BS11RF	BEARING
44	NLE-5302	COLUMN DRIVE TUBE KEY
45	NAL-591	DRIVE MITER GEAR

WHEN ORDERING REPAIR PARTS, GIVE MODEL NO., MACHINE NO. & SERIAL NO.  
AS WELL AS PART NUMBER AND NAME.

NEW WAY PACKAGING MACHINERY, INC.  
P.O. BOX 467 210 BLETTERN AVENUE  
HANOVER, PA. 17331  
TEL. (717) 637-2133 OR 637-8998  
FAX. (717) 637-2966 WEB SITE: [www.labeler.com](http://www.labeler.com)

JULY 15, 2002

MODEL A7RC/APRC L.H. CONTROL LABELER MAIN COLUMN DRIVE ASSEMBLY  
DWG. NO. NAL-A18LRC

ITEM NO.	PART NO.	DESCRIPTION
46	NAL-515	DRIVE TUBE
47	NAL-110	SUPPORT TUBE
48	NAL-17	DISCHARGE END PLATE
49	NAL-1992L	REDUCTION HOUSING EXTENSION
50	NAL-10AL	REAR SIDE PLATE
51	NAL-51	REDUCTION HOUSING
52	NAL-A575RC	MOTOR BELT GUARD ASSEMBLY
53	NAL-10L	MAIN FRAME PLATE
54	NLE-56	COLUMN COVER PLATE
55	NAL-1952	LEG MOUNT BLOCK
56	NAL-1951	LEG MOUNT BLOCK
57	NAL-1950D	LED - DISCHARGE END
58	NAL-W1953LR	LEG EXTENSION WELDMENT
59	NAL-W1953LL	LEG EXTENSION WELDMENT
60	NL-B2230	BEARING
61	NLE-DS353	OIL SEAL
62	NAL-5341L	DRIVE SHAFT SCREW-L.H.
63	NLE-540	DRIVE HOUSING CAP - REAR
64	NLE-5101	DRIVE SHAFT-14 TEETH
65	NLE-DS89	OIL SEAL
66	NLE-BFS180X1	BEARING
67	NAL-573	DRIVE SHAFT BEARING SUPPORT
68	NLE-599	MAIN DRIVE SPUR GEAR- 84 TEETH
69	NLE-55	REDUCTION HOUSING COVER
70	NAL-597RC	PASTE POT DRIVE SHAFT
71	NLE-DS221	OIL SEAL
72	NLE-510	REDUCTION COVER CAP
73	NAL-525	DIAMETER ADJUST SHAFT
74	NAL-546L	DIAMETER ADJUSTMENT CHAIN
75	NA-W536F	CHAIN TAKE-UP BRACKET WELDMENT
76	NAL-517	DIAMETER ADJUSTING SCREW
77	NAL-1999RC	HEIGHT ADJUST SHAFT SUPPORT
78	NAL-A52F	CARRIER FRAME SUPPORT ASSEMBLY
79	NLE-518R	DIAMETER ADJUST SCREW SLEEVE-R.H.
80	NAL-1901	DIAMETER SCREW SLEEVE MOUNT
81	NAL-1902	DIAMETER SCREW SLEEVE SUPPORT
82	NAL-1996	DISCHARGE END SUPPORT TUBE BRACE
83	NAL-1995	DISCHARGE END PLATE FILLER
84	NA-PF12	3/8" NPT B.I. PIPE PLUG
85	NA-PF18	1/2-3/8 NPT B.I. PIPE BUSHING
86	NA-PF10	1/8" NPT B.I. PIPE PLUG
87	NAL-574	DRIVE SHAFT BEARING SUPPORT
88	NAL-575	DRIVE SHAFT BEARING SPACER

WHEN ORDERING REPAIR PARTS, GIVE MODEL NO., MACHINE NO. & SERIAL NO.  
AS WELL AS PART NUMBER AND NAME.

NEW WAY PACKAGING MACHINERY, INC.  
P.O. BOX 467 210 BLETTNER AVENUE  
HANDOVER, PA. 17331  
TEL. (717) 637-2133 OR 637-8998  
FAX. (717) 637-2966 WEB SITE: [www.labeler.com](http://www.labeler.com)